

JR/JR20-PRC

DESCRIPTION

The JUNIOR-PRC and JUNIOR20-PRC models are instruments that accept any voltage or current process signal to measure process variables with direct indication in engineering units. Fully software programmable, the JR-PRC and JR20-PRC provide selectable input type ($\pm 10V$ DC or $\pm 20mA$ DC) and excitation output to feed the transducer @ 24V. Two scaling methods to program the display to match desired application. Optionally, it can be equipped with a 2-relay control output card (2RE).

STRUCTURE

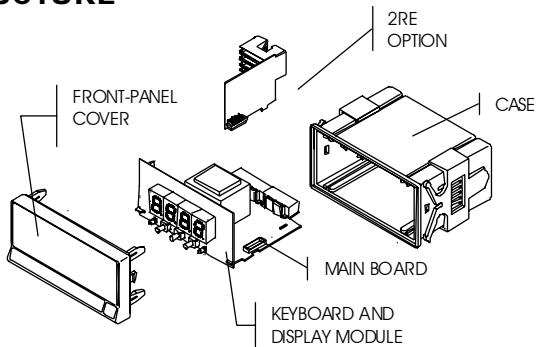

STANDARD

- Panel-mounting 1/8 DIN case, depth 60mm.
- Electronics assembly :
 - Main board.
 - Keyboard and display module.
- Fixing clips for panel mounting.
- Frontal sealing gasket.
- Plug-in terminal block connectors.

OPTIONS

- 2 SPDT relays rated 8A @ 250V ACRef. **2RE**

DIMENSIONS AND MOUNTING

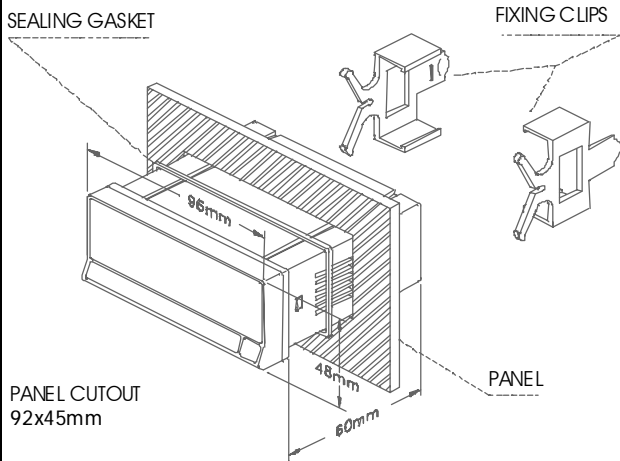

JUNIOR-PRC



JUNIOR20-PRC



CONNECTIONS

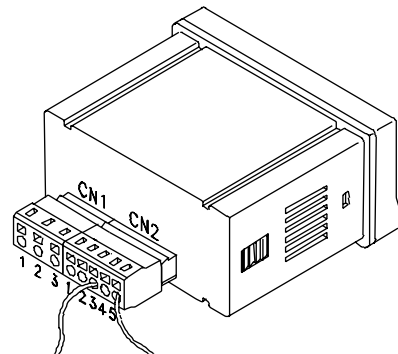

CN1	POWER SUPPLY	
	AC VERSION	DC VERSION
PIN		
1	AC HI	+V DC
2	GND (GROUND)	-
3	AC LO	-V DC
CN2	INPUT SIGNAL	
	INPUT VOLTS	INPUT MILLIAMPERES.
PIN		
1	- INPUT	- INPUT
2	+ INPUT	-
3	-	+ INPUT
4	+ EXCITATION	+ EXCITATION
5	- EXCITATION	- EXCITATION

JR/JR20-PRC

DISASSEMBLY

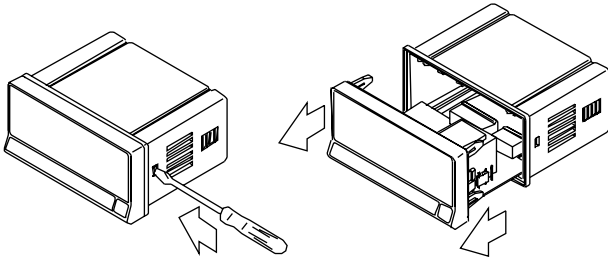

POWER SUPPLY (JUMPER SELECTION)

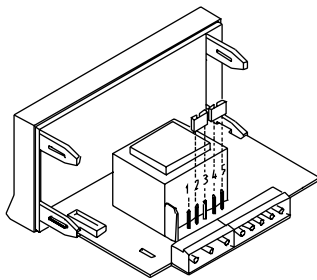
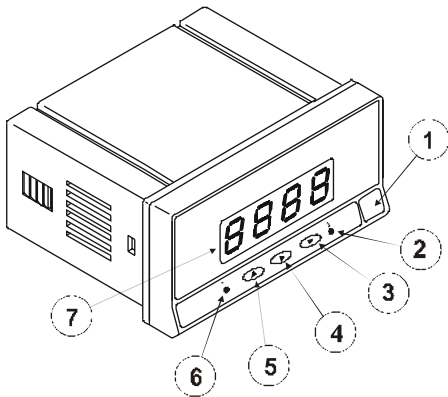

Table 1. Jumper settings.

Pin	1	2	3	4	5
230V AC	-	■	■	■	■
115V AC	■	■	■	■	-
48V AC	-	■	■	■	■
24V AC	■	■	■	■	-

FRONT-PANEL FUNCTIONS



	MODE	RUN	PROG
Label	1	Measurement unit	
Led 2	2	Indicates setpoint 2 is active	Indicates programming of the setpoint2
■ key	3	Shows programming data. Gives access to PROG mode	Validates programmed data. Advances one program step. Exit program mode.
➤ key	4	-	Shifts to the right
▲ key	5	-	Gives access to the setpoint values. Increments the active digit value.
Led 1	6	Indicates setpoint 1 is active	Indicates programming of the setpoint1
Display	7	Displays the variable being measured	Shows programming parameters

INPUT SIGNAL

- Configuration differential asymmetrical
- INPUT VOLTAGE CURRENT
- Input ±10V DC ±20mA DC
- Resolution 0,5mV 10µA
- Input impedance 1MΩ 12.1Ω
- Excitation 20VDC ±5V @ 25mA (@230V)

POWER SUPPLY

- AC voltages 115V/230V 50/60Hz (±10%)
24V/48V 50/60Hz (±10%)
- DC voltages 12V (10.5 to 16V) DC
24V (21 to 32V) DC
48V (42 to 64V) DC
- Consumption 3W

ACCURACY

- Max error ± (0.1% of the reading + 3 count)
- Temperature coefficient ±100ppm/°C
- Warm-up time 5 minutes
- Step response time 250ms

FUSES (DIN 41661) (Recommended)

- JR/JR20-PRC (115/230V AC) F 0.1A / 250 V
- JR/JR20-PRC2 (24/48V AC) F 0.2A / 250 V
- JR/JR20-PRC3 (12V DC) F 1A / 250 V
- JR/JR20-PRC4 (24V DC) F 0.5A / 250 V
- JR/JR20-PRC5 (48V DC) F 0.5A / 250 V

A/D CONVERSION

- Technique Sigma-Delta
- Resolution ±15bit
- Read rate 25/s

DISPLAY

- Range for:
JR-PRC -9999/9999, 14 mm red digits
JR20-PRC -1999/9999, 20 mm red digits
- Decimal point programmable
- LED's 2 output status
- Display update time 250ms
- Over range indication Ove

ENVIRONMENTAL

- Working temperature -10 °C to +60 °C (0°C to 50°C) s/UL
- Storage temperature -25 °C to +85 °C
- Relative humidity <95% at 40°C
- Altitude max. 2000 m

MECHANICAL

- Dimensions 96 x 48 x 60 mm
- Weight 250g
- Case material UL 94 V-0 polycarbonate
- Sealed front panel IP65 (Indoor use)

ORDERING REFERENCES

- 115/230V AC 50/60Hz powered JR/JR20-PRC
- 24/48V AC 50/60Hz powered JR/JR20-PRC2
- 12V DC powered JR/JR20-PRC3
- 24V DC powered JR/JR20-PRC4
- 48V DC powered JR/JR20-PRC5

2RE - 4RE - 4OP - 4OPP

9.1 SETPOINTS

TWO SPDT

FOUR SPST

FOUR NPN

FOUR PNP

DESCRIPTION

An option of 2 or 4 SETPOINTS, programmable within the full display range, can be incorporated to the unit thus providing alarm and control capabilities by means of individual LED indicators and relay or transistor outputs.

The option consists of a plug-in additional card that once installed in the meter's main board, activates its own programming module.

All the setpoints provide independently programmable values, time delay (in seconds), asymmetrical or symmetrical latch (in counts of display) and selectable HI/LO acting. The setpoints are also configurable to activate independently (each one activates at its corresponding programmed value) or tracking one another.

INSTALLING THE CARD

The setpoint option is supplied independently with its own instructions manual and wiring accessories. The option must be installed in the M5 location. It may be convenient to solder the card to the main board making use of the copper tracks on both sides of the card pin and around the main board hole on its solder side.

INSTALLING THE CARD

Refer to the manual of each model: JUNIOR, MICRA, ALPHA, BETA, GAMMA or KAPPA

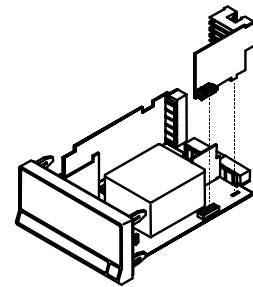

2RE RELAY OPTION

- Max current (resistive load)..... 8A
- Max power2000VA/192W
- Max voltage 250VAC/150VDC
- Contact resistanceMax. 3mΩ
- Output response time Max. 10ms

ORDERING REFERENCE
2 SPDT RELAYS 8A..... **2RE**

2RE - CONNECTION

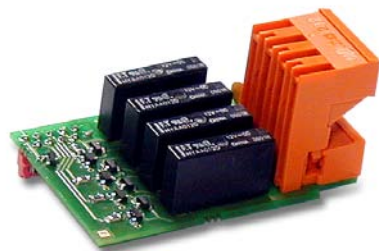
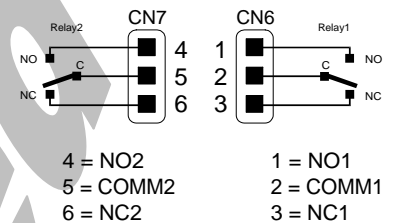

4RE RELAY OPTION

- Max current (resistive load)..... 5A
- Max power1250 VA/ 150 W
- Max voltage 277 V AC/ 125 V DC
- Contact resistance.....max. 30 mΩ
- Output response timemax. 10 ms

ORDERING REFERENCE
4 SPST RELAYS 5 A **4RE**

4RE - CONNECTION

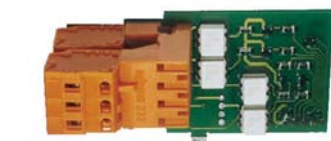
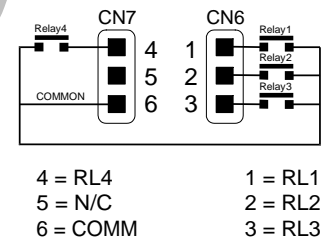

4OP TRANSISTOR OPTION

- Max current (resistive load).... 50mA
- Max voltage50VDC
- Leakage current Max. 100μA
- Output response time Max. 1ms

ORDERING REFERENCE
4 NPN opto-coupled outputs **4OP**

4OP - CONNECTION

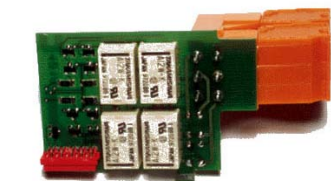
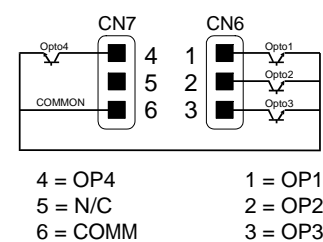

4OPP TRANSISTOR OPTION

- Max current (resistive load).... 50mA
- Max voltage50VDC
- Leakage current Max. 100μA
- Output response timeMax. 1ms

ORDERING REFERENCE
4 PNP opto-coupled outputs..... **4OPP**

4OPP - CONNECTION

